

BALEMAT 2

THE 2ND GENERATION AUTOMATIC BALE TESTER

PTS technology inside

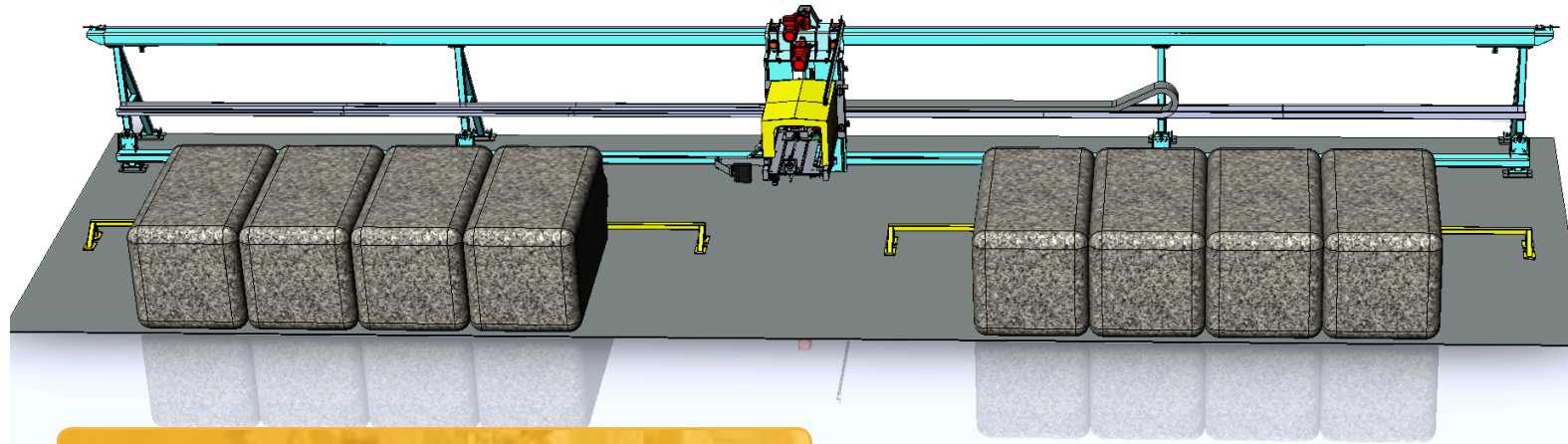

- + Calibrated data for moisture, plastics, fibers & ash
- + Automatic, operated by the forklift drivers
- + Simatic S7 PLC with local language user interface
- + Profinet industrial internet with remote support
- + Optional remote control by a radio system
- + The best NIR-analytics available on the market
- + Easy to maintain & service, automatic calibration
- + Efficient projects due to modular design

The 2-area system maximises the capacity by minimizing idle time - testing can proceed while bales are loaded on the other area.

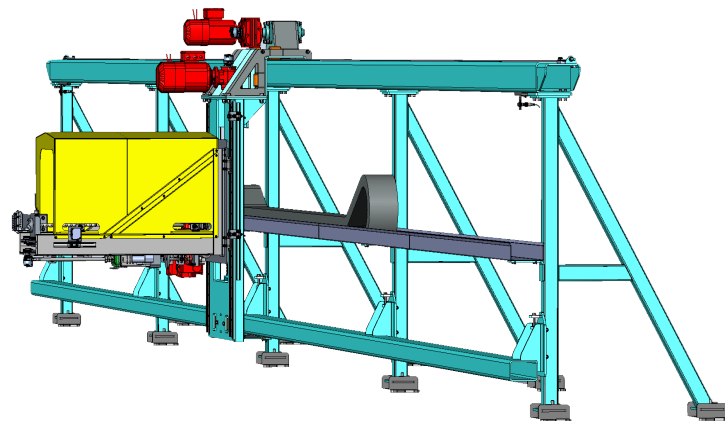

HAARLA ENGINEERING IS A PART OF HAARLA GROUP WHO HAS SINCE 1961 OPERATED IN THE INDUSTRY AS A SOLID PARTNER AND SUPPLIER OF CHEMICALS, RAW MATERIALS AND EQUIPMENT. HAARLA EMPLOYS PEOPLE IN FOUR COUNTRIES AND SELLS ITS PRODUCTS ALL OVER THE WORLD.

HAARLA ENGINEERING FOCUSES ON INNOVATING NEW AND RELIABLE INDUSTRIAL APPLICATIONS. WE DEVELOP THINGS YOU HAVEN ' T EVEN BEEN THINKING ABOUT... AND THAT APPROACH MEANS TYPICALLY COMBINING THE VERY BEST FROM OUR PARTNERS IN TECHNOLOGY, PROFESSIONALS FROM VARIOUS FIELDS WITH OUR OWN PRACTICAL EVERYDAY ENGINEERING - THINKING. WHY SHOULD WE MAKE SYSTEMS WITH LOADS OF EXOTIC THINGS, IF WE CAN USE MORE COMMON TECHNOLOGIES THAT OUR CUSTOMERS ALLREADY KNOW AND MANAGE??

THE BASICS

"What does your recycled fiber delivery really contain?? You pay for the fiber or are you losing money on buying too much water, too much plastics or too much ash?" Also, how does the delivered material influence your process??

The RCF bales are hard to work with and they not only contain fiber, but also foreign materials like domestic waste, metal and even stones. Manual bale testing is very slow and demanding work - and the Balemater solves these issues also providing automated data management of the valuable data.

The system delivers reliable data to the production management, quality management and procurement which will all in their own fields manage benefit of the results.

THE BALEMAT 2 SYSTEM

"Test several bales in just 90 seconds each and transfer the test results automatically without a need for a dedicated system operator" is what the system aims at in short terms. Speed is adjusted according the bale properties

The forklifts unloading the trucks will manage the loading of the bales to the BALEMAT. "Load bales against the system buffer and press start" -results a green traffic light when it is safe to take the bales out again with data automatically available.

The touch-screen user interface allows for manipulating the system parameters and system status viewing.

The system allows for the production & quality management as well as the procurement to benefit of the data practically instantly.



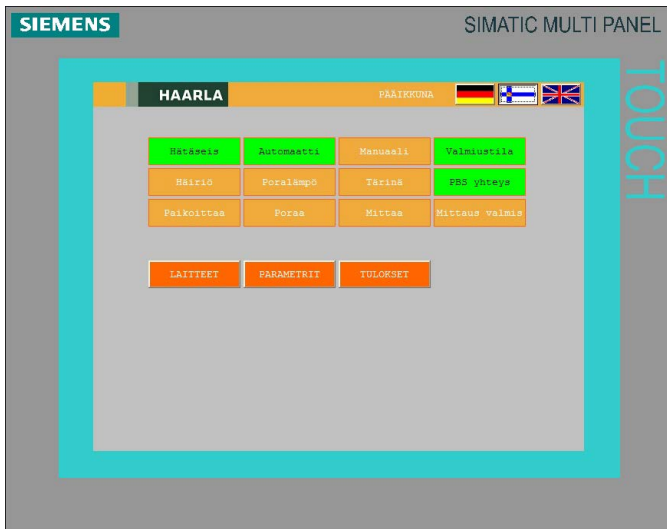

THE DRILLING SOLUTION

We developed a powerful, modular drilling system that can house practically any type of drill and is easily serviceable. We modified our own drill bit which is able to manage the high forces and it works on most of the materials. Also a tubular core drill was developed, but was abandoned as impractically expensive.

The moving system frame can optionally be equipped with cleaning blades, which together with a easy to install flat floor plate under the system make the system push waste to one side of the safety area for easy collection.

SYSTEM INTELLIGENCE

Ensuring personnel & fire-hazard -safety and also the system health, a vast number of controls & sensors are used:

- Movements with full position awareness allowing flexibility
- Bale position, size, number, distance measured
- Detection of metal bands
- Automatic drilling speed & torque control
- Intelligent drilling sequence with dynamic torque & speed
- Drill head temperature monitoring, alarm & stop levels
- Drill head breaking monitor & automatic stop
- Drill bed vibration monitoring and alarms
- NIR-sensor manipulation force monitoring
- No movements unless NIR-sensor in a safe position
- Field approved, two level safety screens
- Optional wireless cameras & screen transfer are available

The automation ensures, that the system halts & alarms before system damage or a bale fire hazard condition is generated.

SOLID & CALIBRATED RESULTS

The PTS sensor is the best solution on the market for verified measurements of bales. With experience from optical instruments, Haarla solved the problems of bringing a laboratory level optical measurement including calibration standards to an autonomously operating system in the field.

We generated a system where the calibration standard is kept clean & stable for long periods at a time.

With a stable & calibrated accuracy of for instance $\pm 0.5\%$ for moisture and proven numbers for the other parameters, the BALEMAT is a solid performer.

System generics:

- Industrial engineering, standard components, no exotics
- No hydraulics, no pneumatics = no related troubles
- Siemens S7-1200 core, touch screen interface
- Weather proof operating panel, optional radio-control
- NIR-spectrum sensor from PTS, PC-data server & controls
- Sample identification by barcode or manual input
- Max 6 kw intake, low generic power consumption
- Rapid installation & commissioning
- Can be extended to manage any number of bales at a time
- The Balemat2 can at an additional expense be delivered to fit just about any mill standards.
- All deliveries come with Tosibox safe remote access solution with access to all relevant system components.
- Full mill data-system integration is possible at cost. As standard, the data is available in a network folder as TAB-separated text files

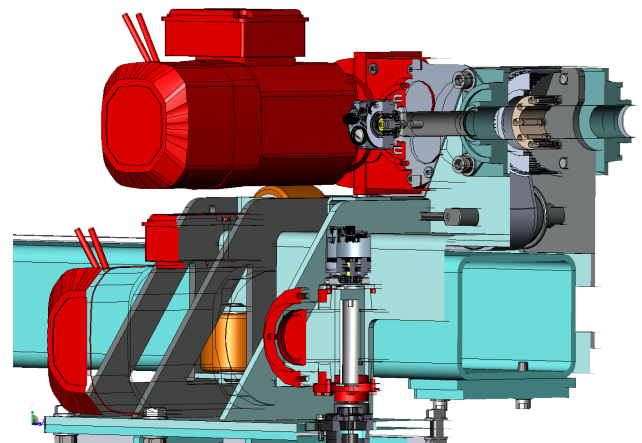

With no "off the shelf" solutions offering the field robustness & care-free service we wanted, we decided to design the travel & transmission system by ourselves.



Typical BALEMAT - project proceedings...

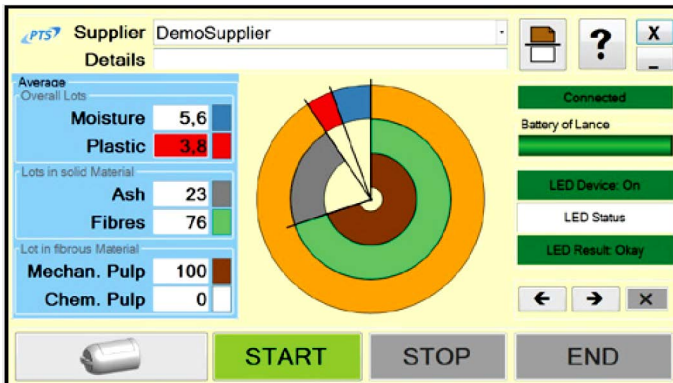

Often the manual bale sensor is piloted at the customer so that the excellent results of the technology can be verified.

After the initial phase, a plan needs to be set up for the requirements of a BALEMAT system. This involves people from the production, the materials reception, data management and procurement as all of these departments are going to enjoy the benefits of the installation.

A customer specific plan is made for the installation, as some customers have just an open space at the edge of the material reception area to offer for the system, while others want to have it installed on the wall of a larger hall.

The BALEMAT concept is flexible and it can be installed in just about any environment. The system is built on order and then it is tested at the Haarla Engineering test track using our bales with mixed office-, carton and publication material bales. We deliver a "hot system" meaning it has already been proved to work as it should.

HAARLA NEWS: The patented ZRI- machinery concept improves Your DIP yield

BACKGROUND

The material efficiency of the deinked pulp production is only moderate as up to 25% of incoming material can end up as reject due to the limited selectivity of the deinking processes.

The rejected streams not only contain contaminants but also some valuable components like fibers, fines, and fillers. Fine-screening reject can consist of over 60% of the most valuable long fibers with good brightness. As the cost of quality recovered paper continues to increase, the loss of valuable material in the form of rejects is becoming both environmentally and economically unacceptable.

ZRI-CONCEPT

Material recovery from rejects would be desirable in order to improve the material efficiency of deinked pulp production. Analyses of deinking rejects have shown potential for material recovery in particular from fine-screening rejects.

Haarla Oy has developed and patented a method for the recovery of valuable fibers from fine-screening rejects.

The method includes modification of the macro-sized (<math><150\mu\text{m}</math>) hydrophobic contaminants with ZRI-reactor and removal of them by selective flotation. The ZRI-reactor fragments contaminants and modifies the surfaces of contaminants with both mechanical and ultrasonic conditioning. ZRI-reactor treats the contaminants very efficiently but does not damage fibers. By this patented concept, 80% of the fibers from fine-screening reject can be recovered implying at least a 1-1.5 percentage units increase in yield

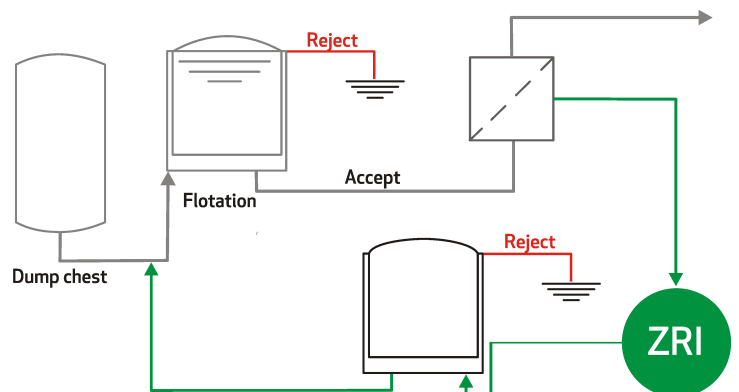

Haarla Engineering Oy
Leijerintie 3
53500 Lappeenranta
Finland
www.haarla.fi

Haarla Engineering sales
mr. Jarkko Haarla Jr
tel. +358 3 3399 1300
GSM +358 40 544 3235
email: jarkko.haarla@haarla.fi

PTS - The paper & board specialists
mr. Jörg Hempel
tel. +49 3529 551 659
GSM +49 172 8695 459
email: joerg.hempel@ptspaper.de